





# SUMMARY

OUR BLINDS	4 - 5
OUR RANGE	6 - 19
OUR PROCEDURES	20 - 25
OUR REFERENCES	26 - 27

# THE MANUFACTURE



In **France**, at the Emerainville site, each blind is hand-made, customized according to a recognized expertise and appreciated in order to improve the comfort and well-being of people.



**1** SELECTION OF MATERIALS

Our films are selected both for their colour and their specific properties



**2** CUSTOMIZED WORK

All films, all sizes, all forms, each request finds its solution.



**3** ASSEMBLY

Each order requires precision and control, films and mechanisms are assembled manually.



**4** 100% TESTED

For the sake of quality and customer satisfaction, all our blinds are tested before each shipment.



Expertise which has now lasted more than 30 years

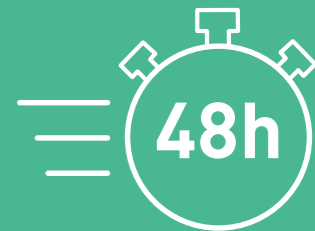

Pattern delivered in 48h



A large distributor network throughout France



The heat is highly harmful to the productivity, comfort and health of people.

This is a major problem growing each year in companies

SOLUTION



# SHADE FILM

Fabric



- Film especially developed to **reduce the temperature.**
- Up to **92%** of heat rejected.
- Allows **good visual continuity** on the outside.



**WARMTH**  
issue?



**GLARE**  
issue?

Glare is a real problem for concentration and productivity.

This can lead to headaches, more intense eye work and poor quality work.

**SOLUTION**



# SOLTIS 99

Film  
by Serge Ferrari



- Up to **97%** of heat rejected.
- **21 colours** available in stock.
- Optimizes **comfort** in terms of design and warmth.





Interior decoration is important, it makes the work environment more pleasant, feel better and therefore more productive.

SOLUTIONS

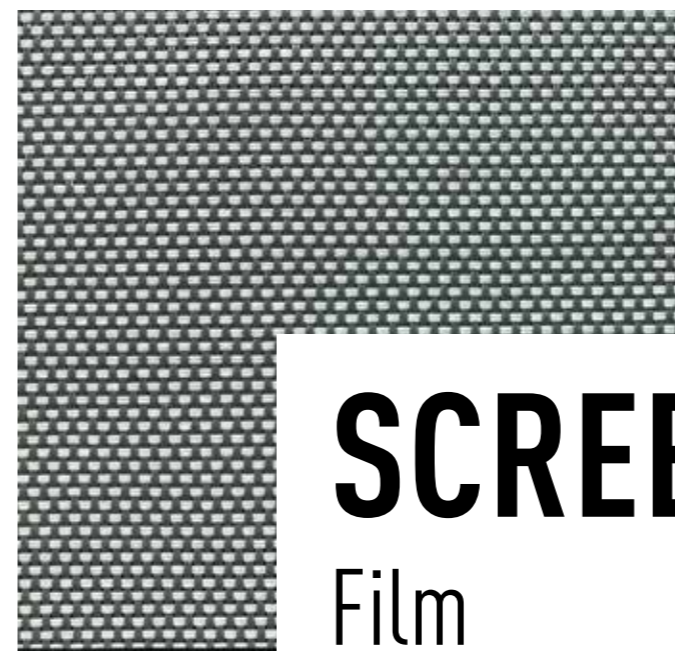

# SCREEN VISION

Film  
by Mermet



- Offers **visual and thermal comfort**.
- **14 colours** available in stock.
- Weaving mats for **optimal transparency**.



Need for  
**CHANGE?**



**PRIVACY**  
issue?

At work, in offices, we do not always want to be observed.

For reasons of confidentiality, privacy must be respected.

SOLUTION

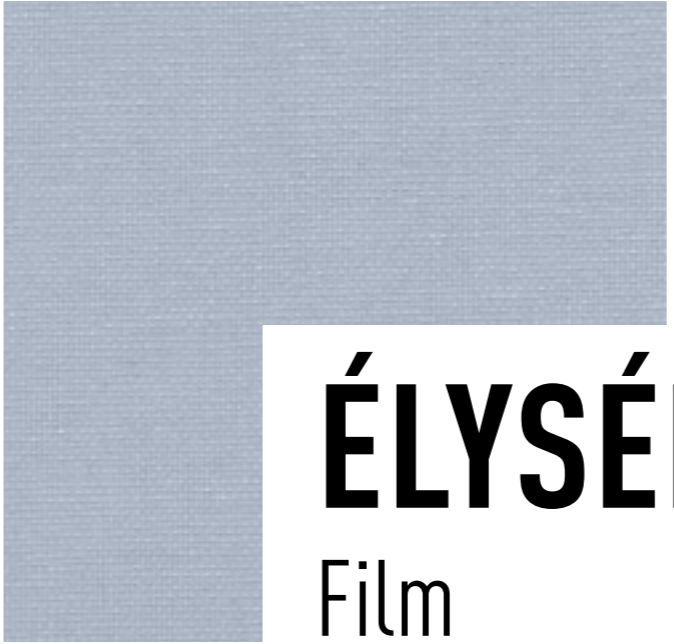

# ÉLYSÉE

Film



- To be able **to hide** from the vis-à-vis.
- **Cover** their workspace.
- **21 colours** available.





Too much light in a room can sometimes be disturbing.

There are other devices than external shutters to obtain total darkness.

SOLUTION

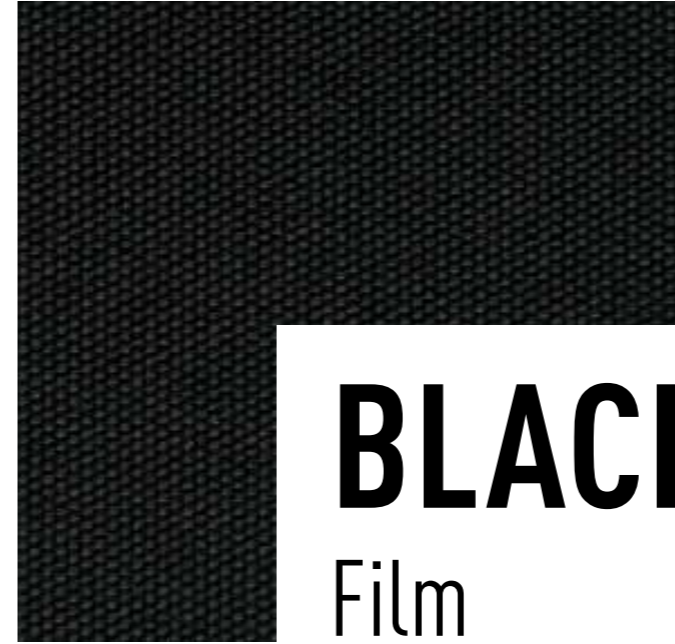

# BLACKOUT

Film



- Allows **total darkness** of a room.
- Available in **large widths** to avoid fittings.
- **6 colours** available .



Need  
**DARKNESS?**





Need to  
**SEE WITHOUT BEING SEEN?**

The problem of external privacy is important at work.

The need to combine discretion and design reassures while being appreciated by all.

SOLUTION

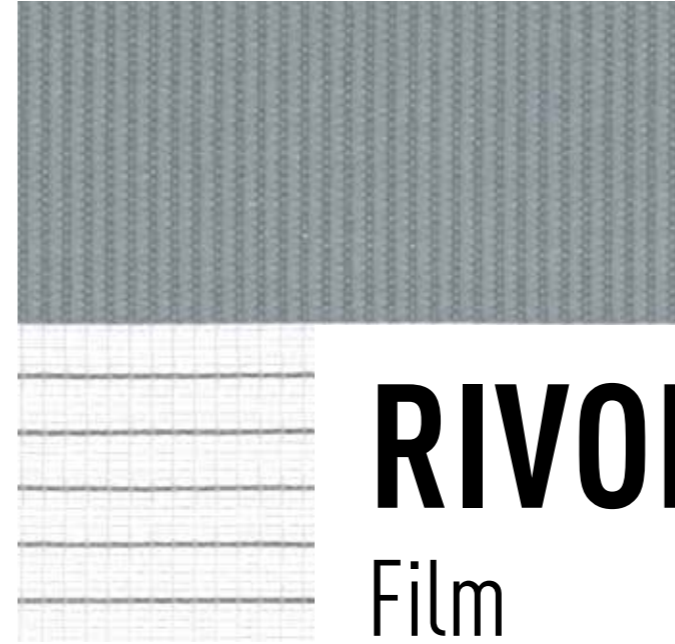

# RIVOLI

Film



- **2 possible** positions: day and night to combine brightness and discretion.
- **7 colours** available.
- The **design touch** for your interior.



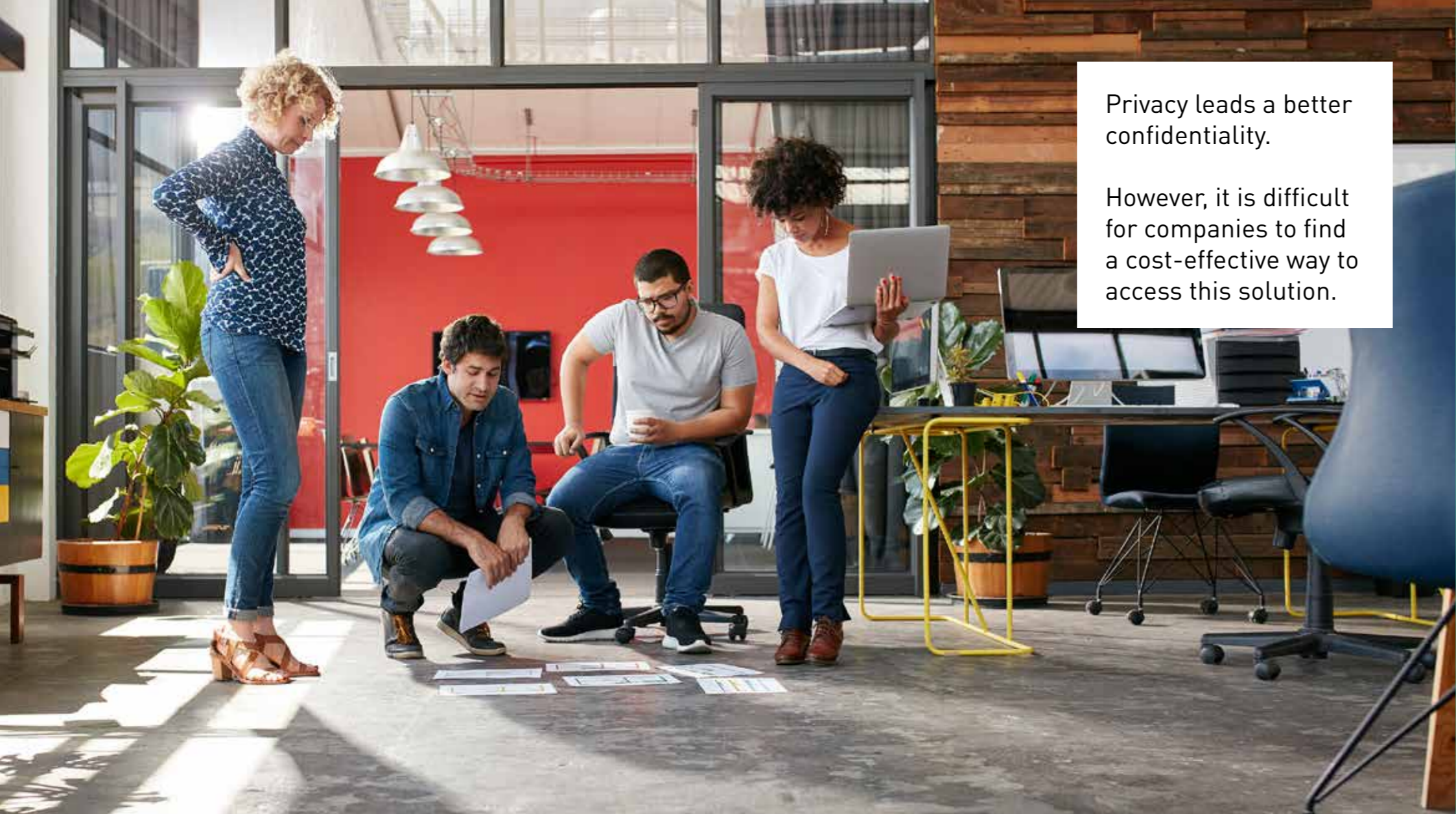

Privacy leads a better confidentiality.

However, it is difficult for companies to find a cost-effective way to access this solution.

SOLUTION

Need a  
**COST-EFFECTIVE SOLUTION?**



# VÉNITIEN

## Blind



- Contributes to intimacy and is **unoverlooked**.
- **Integrates easily** into frames.
- More than **100 colours** available.



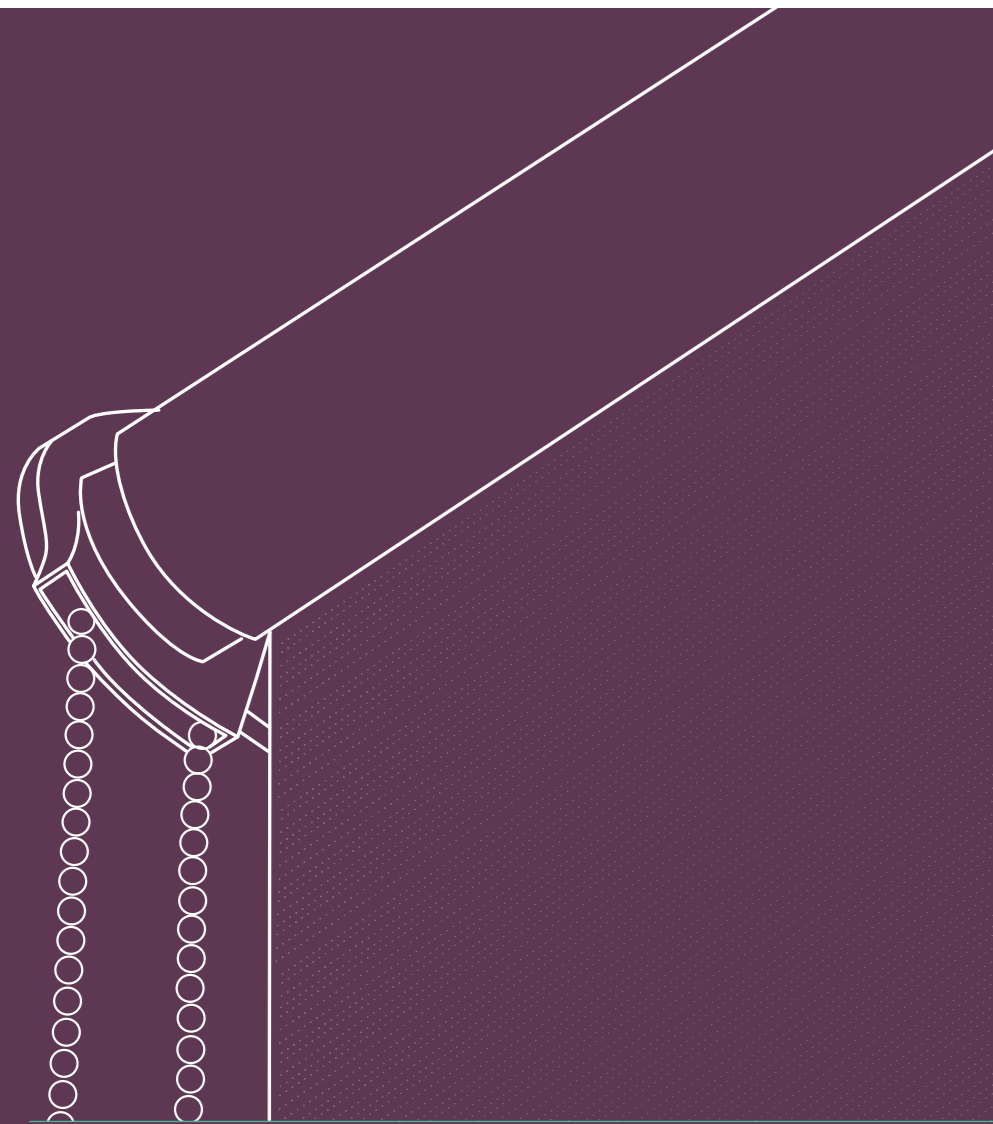

4m  
 MAXIMUM  
 SIZE  
 4,5m

# REWINDER- BLINDS

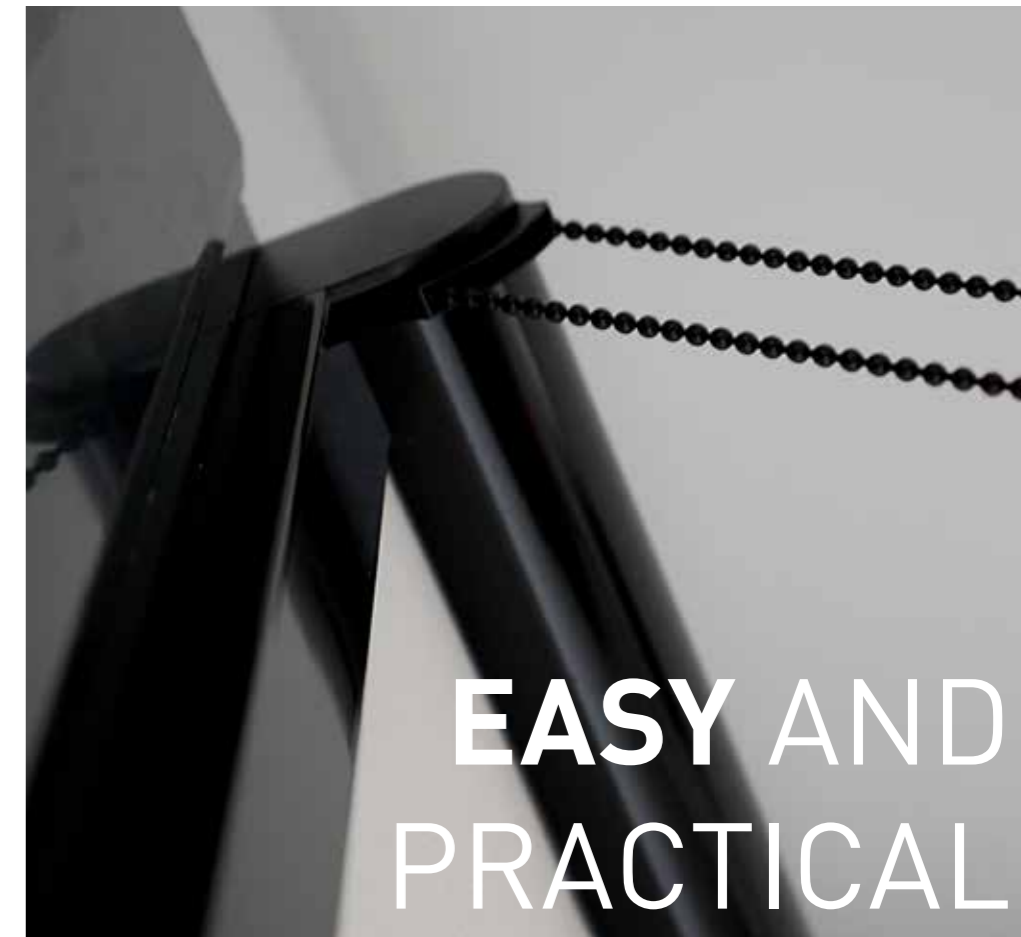

**EASY AND  
PRACTICAL**

## OPTIONS

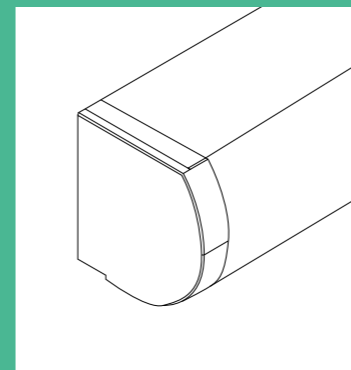

BOX

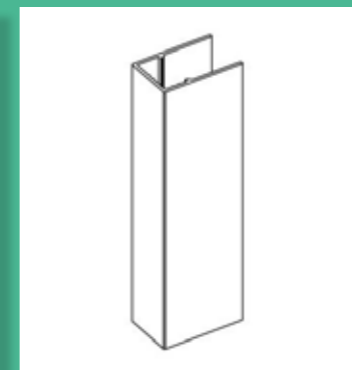

U OR BLACKOUT SIDE  
PROFILE

## MECHANISMS



NICKEL OR PVC BALL CHAIN

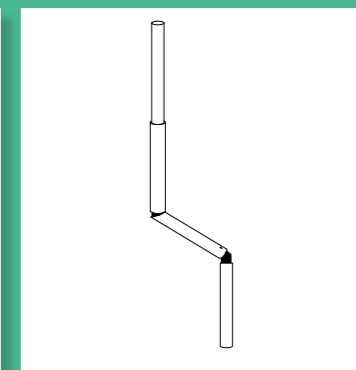

CRANK HANDLE

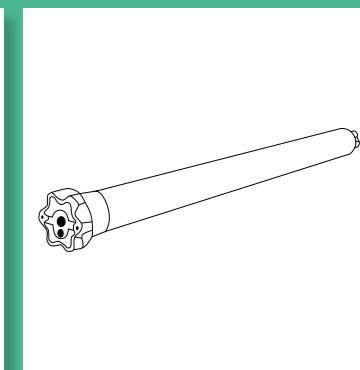

ENGINE

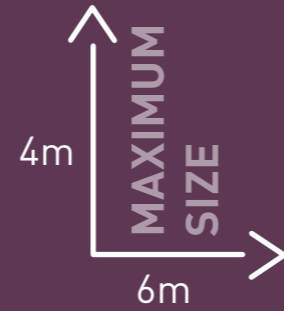
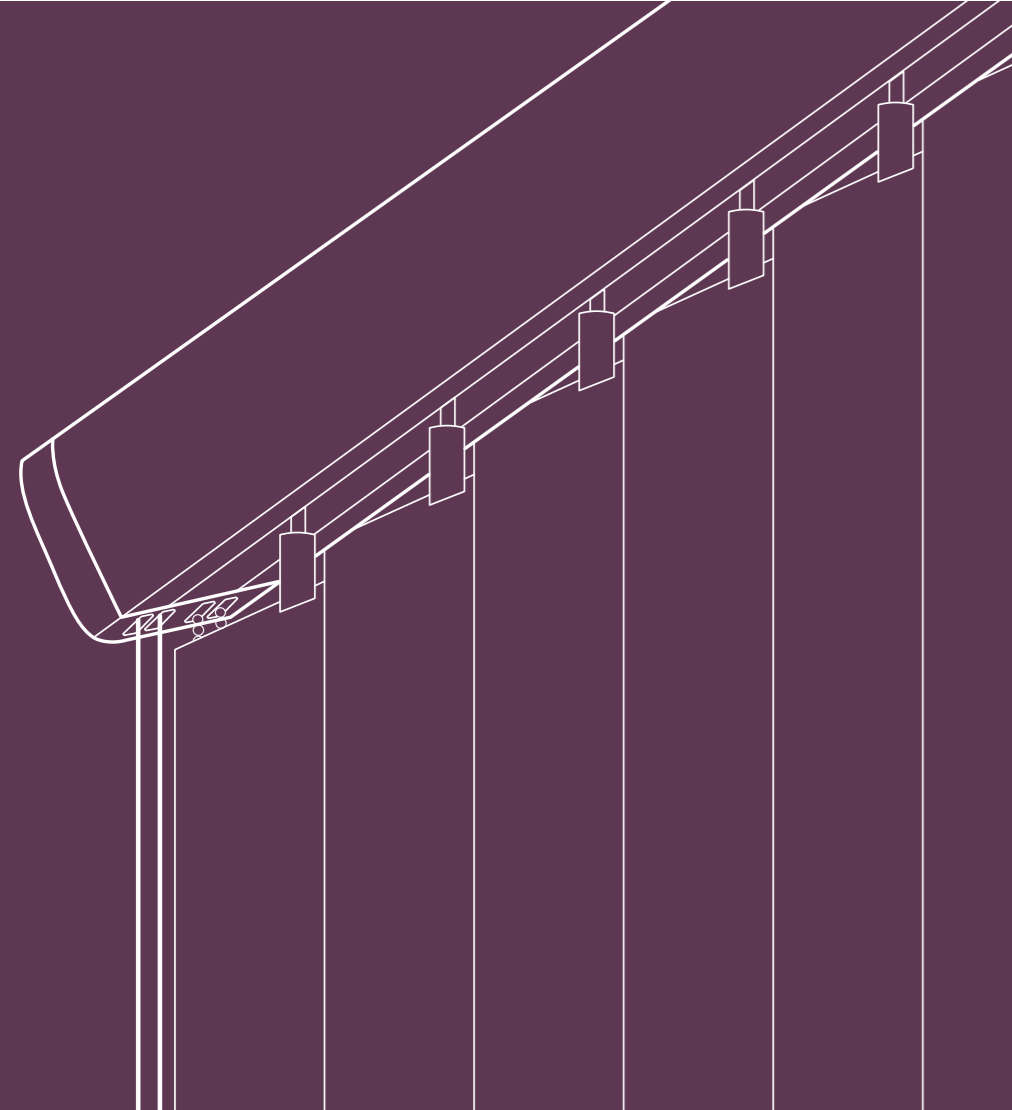

# VERTICAL BLINDS



PERFORMANCE  
AND FLEXIBILITY

## OPTIONS

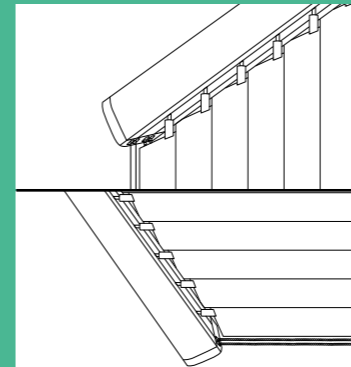

VERTICAL OR HORIZONTAL

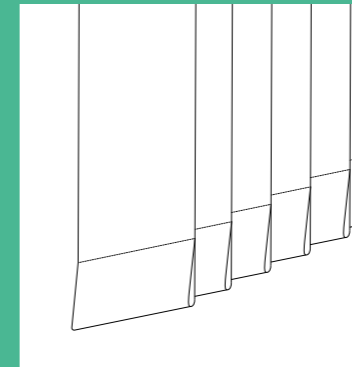

89, 127 OR 250MM

## MECHANISMS

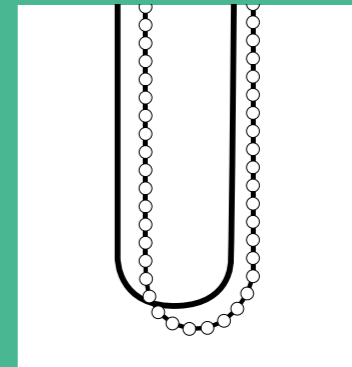

CORD AND BALL CHAIN



SINGLE COMMAND  
MECHANISM

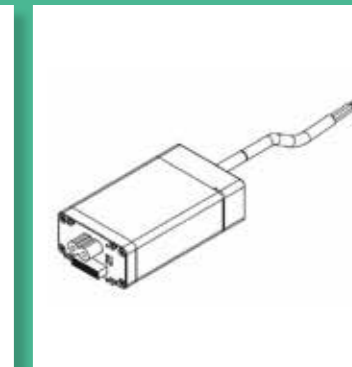

ENGINE

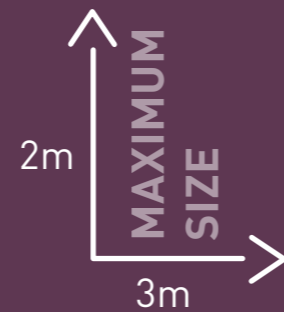
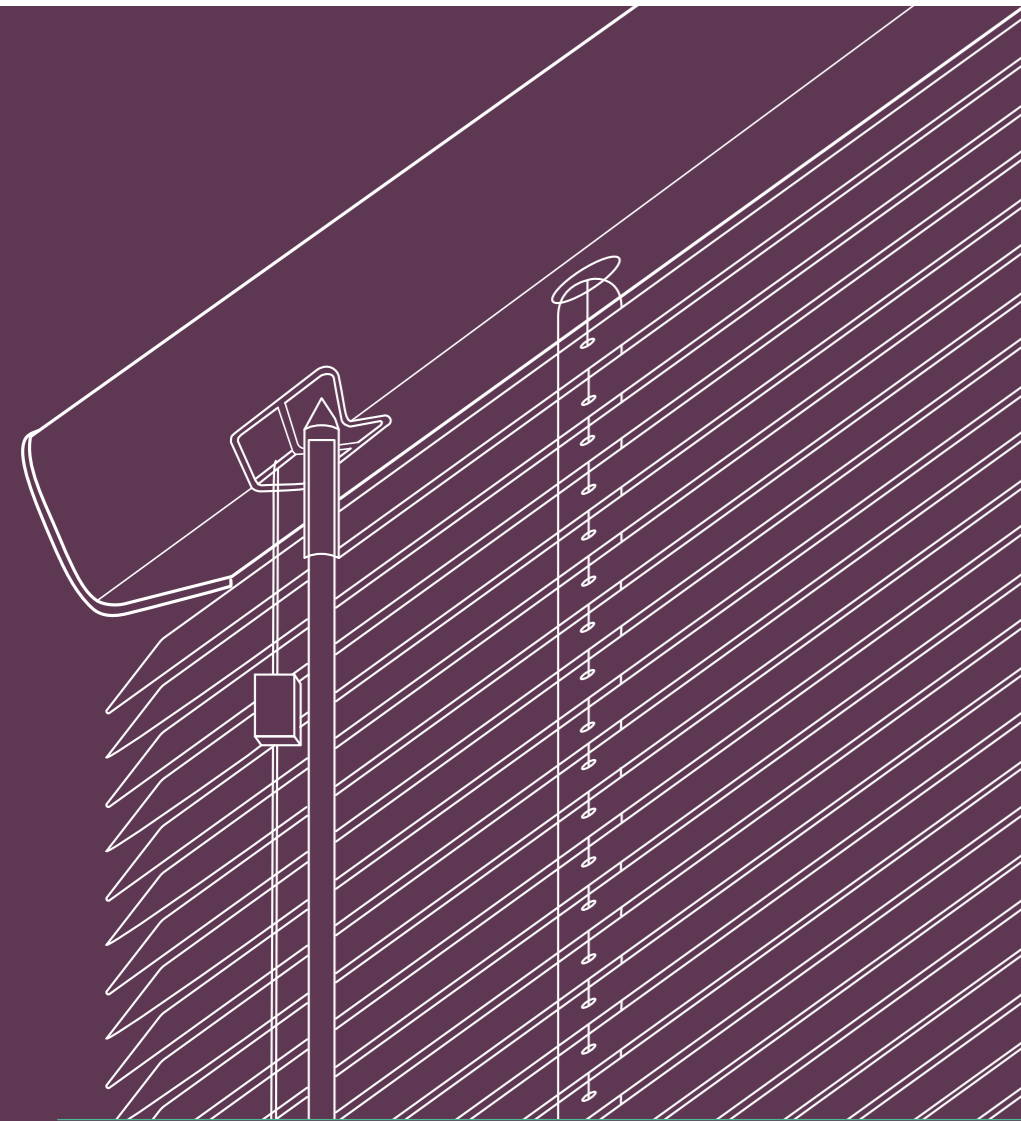

# VÉNITIEN BLINDS



## STYLE AND LIGHT EFFECTS

### OPTIONS

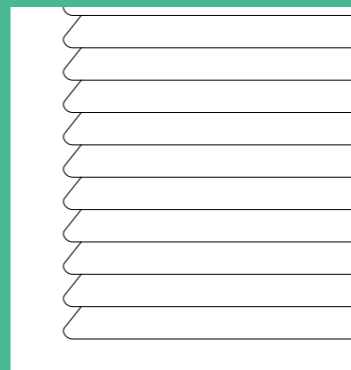

15MM, 25MM OR 50 MM

### MECHANISMS

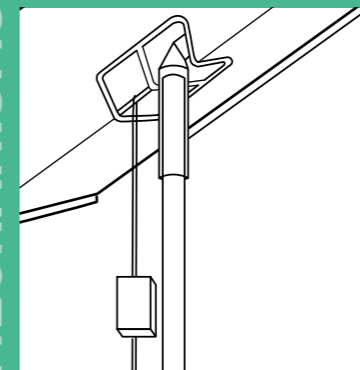

CORD AND ROD



SINGLE COMMAND BALL  
CHAIN

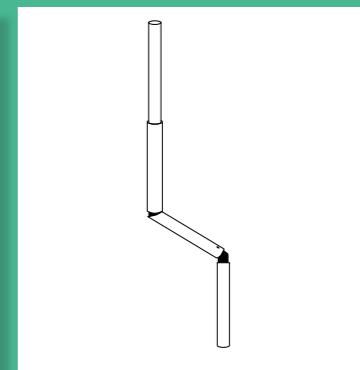

CRANK HANDLE

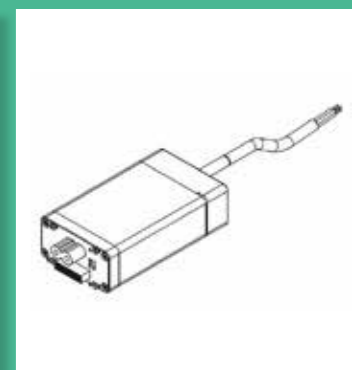

ENGINE



**1** European Parliament  
Strasbourg  
*300 Shade-Films*

**2** Town hall of  
Saint Denis Paris  
*1000 Shade-Films*

**3** AXA  
Brussels  
*6000 Shade-Films*

**4** Amazon  
Barcelona  
*1500 Shade-Films*





---

**SOLAR GARD ENTERPRISES LTD.**

Unit 5, Karlbrook Enterprise Park,  
Doughcloyne Industrial Estate,  
Wilton,  
Cork.

Tél. : 021 4545606